

Espagnolettes for windows

Instructions for milling. Measurements in mm.

S1604 with 2 side bolts

L	H	a	b
390	195	80	310
490	245	80	410
590	295	125	465
690	345	125	565
790	395	200	590
890	445	200	690
990	495	200	790
1090	545	200	890
1190	595	200	990

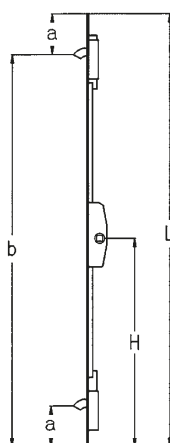

S1604 with 3 side bolts

L	H	a	b	c
1290	645	200	1090	580
1390	695	200	1190	630
1490	745	200	1290	680

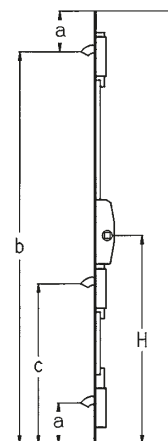

Made-to-measure espagnolettes

S1601 with 2 side bolts

L	a
500-589	80
590-999	125

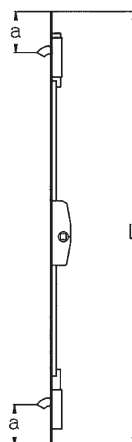

S1601 with 3 side bolts

L	a	b
1000-1899	125	65

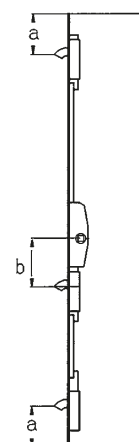

S1605 with 2 side bolts

L	a
500-589	80
590-999	125

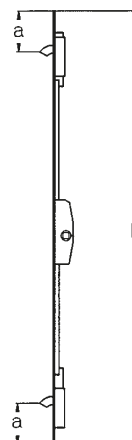

S1605 with 3 side bolts

L	a	b
1000-1899	125	65

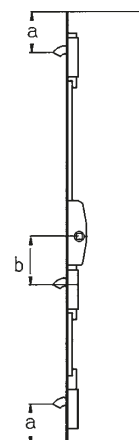

Espagnolettes for windows

Instructions for milling. Measurements in mm.

S1161 with 2 side bolts

L	H	a	b
388	194	55	333
488	244	80	408
588	294	125	463
688	344	125	563
788	394	125	663
888	444	125	763
988	494	125	863
1088	544	225	863
1188	594	225	963
1288	644	225	1063
1388	694	225	1163
1488	744	225	1263

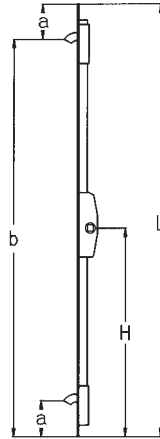

S1161 with 2 side bolts, and casement stay

L	H	a	b
788	394	125	663
888	444	125	763
988	494	125	863
1088	544	225	863
1188	594	225	963
1288	644	225	1063
1388	694	225	1163
1488	744	225	1263

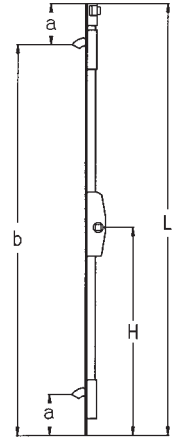

S1163 with 2 side bolts

L	H	a	b
450	225	80	370
750	375	80	670
1050	525	80	970

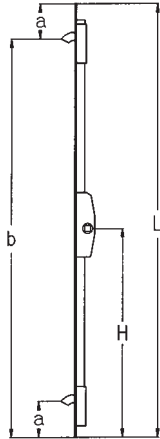

S1163 with 3 side bolts

L	H	a	b	c
1350	675	80	1270	610

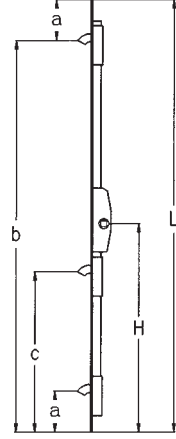

S1164, S1165 with 2 side bolts

L	H	a	b
485	242	55	430
685	342	55	630
885	442	55	830

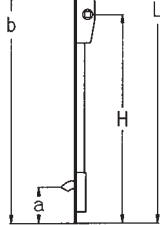

S1164, S1165 with 3 side bolts

L	H	a	b	c
1085	542	55	1030	477
1285	642	55	1230	577

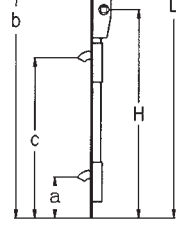

S1162 with 3 side bolts

L	H	a	b	c
1088	544	125	963	479
1188	594	125	1063	529
1288	644	125	1163	579
1388	694	125	1263	629
1488	744	125	1363	679

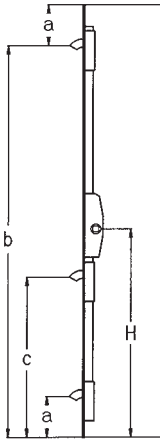

S1166, S3157 with 3 side bolts

L	b
1915	1790
2015	1890
2115	1990
2215	2090

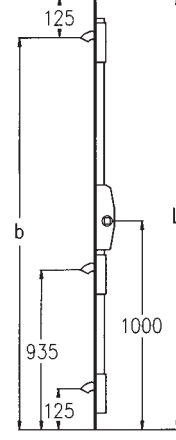

S1167, S3158 with 3 side bolts

L	b
1915	1790
2015	1890

Made-to-measure espagnolettes

Instructions for milling. Measurements in mm.

S1151 with 2 side bolts

L	a
430–549	80
550–999	125
1000–1499	225

S1151 with 2 side bolts, and casement stay

L	a
550–999	125
1000–1499	225

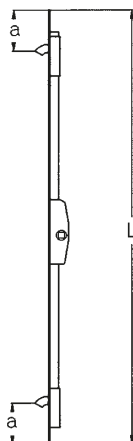

S1151 with 3 side bolts

L	a
1500–2299	65*

S3151 with 3 side bolts

L	a
1500–2299	65*

S3251 with 3 side bolts

L	a
1500–2299	65*

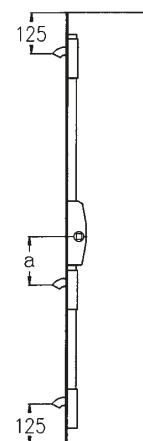

S8457 with 3 side bolts

L	a
1500–2299	L/2

Normal handle height = 1000-1600

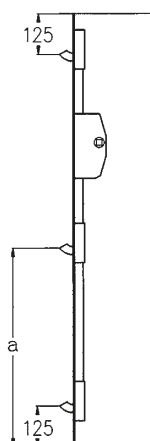

S1151 with 3 side bolts, and casement stay

L	a
1500–2299	65*

S3151 with 3 side bolts

L	a
1500–2299	65*

S3251 with 3 side bolts

L	a
1500–2299	65*

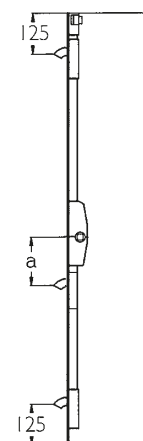

*) Applies to handle height (H) = centre plus/minus 235 mm. For other handle heights, the bolt is positioned at the centre of the espagnolette length.

Made-to-measure espagnolettes

Instructions for milling. Measurements in mm.

S2151 with 2 side bolts, hook bolt type

L	a	d
590–999	125	125
1000–1499	225	225

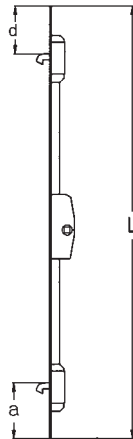

S4251 with 3 side bolts, of which 2 wedge bolts and 1 hook bolt

L	a
1500–1799	210*

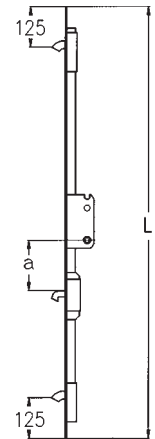

S2151 with 2 side bolts, hook bolt type

L	a	d
660–999	125	160
1000–1499	225	225

S2151 with 3 side bolts, of which 2 wedge bolts and 1 hook bolt

L	a
1500–1799	90*

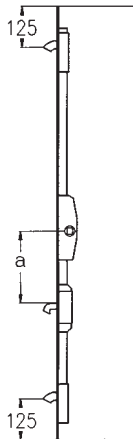

S4151 with 3 side bolts, of which 2 wedge bolts and 1 hook bolt

L	a
1500–1799	65*

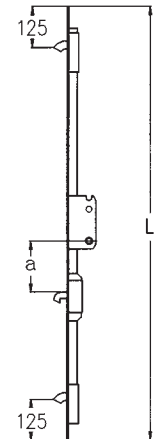

S2151 with 4 side bolts, of which 2 wedge bolts and 2 hook bolts

L	a
1800–2099	600
2100–2299	700

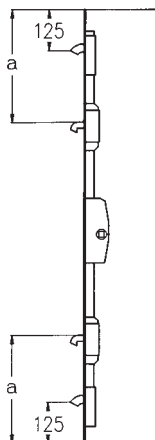

S4151 with 4 side bolts, of which 2 wedge bolts and 2 hook bolts

L	a
1800–2099	600
2100–2299	700

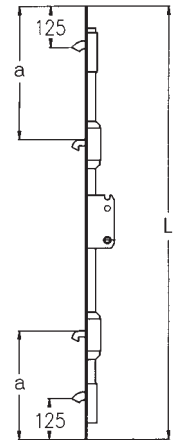

S4251 with 4 side bolts, of which 2 wedge bolts and 2 hook bolts

L	a
1800–2099	600
2100–2299	700

*) Applies to handle height (H) = centre plus/minus 235 mm. For other handle heights, the bolt is positioned at the centre of the espagnolette length.

Made-to-measure espagnolettes

Instructions for milling. Measurements in mm.

S1451 with 2 end bolts and 1 side bolt

L	a
550-1799	65*

S3451 with 2 end bolts and 1 side bolt

L	a
550-1799	65*

S3551 with 2 end bolts and 1 side bolt

L	a
650-1799	65*

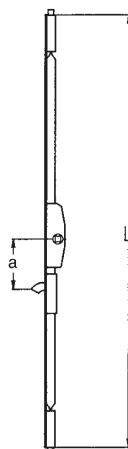

S1451 with 2 end bolts and 2 side bolts

L	a
1800-1899	550
1900-2099	650
2100-2299	750

S3451 with 2 end bolts and 2 side bolts

L	a
1800-1899	550
1900-2099	650
2100-2299	750

S3551 with 2 end bolts and 2 side bolts

L	a
1800-1899	550
1900-2099	650
2100-2299	750

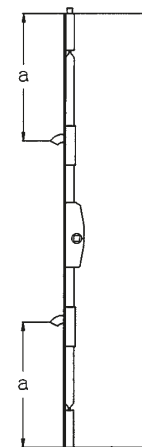

S2451 with 2 end bolts and 1 side bolt, hook bolt type

L	a
640-1799	90*

S4451 with 2 end bolts and 1 side bolt, hook bolt type

L	a
600-1799	65*

S4551 with 2 end bolts and 1 side bolt, hook bolt type

L	a
880-1899	210*

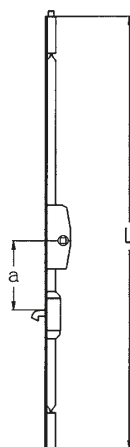

S2451 with 2 end bolts and 2 side bolts, hook bolt type

L	a
1800-1899	550
1900-2099	650
2100-2299	750

S4451 with 2 end bolts and 2 side bolts, hook bolt type

L	a
1800-1899	550
1900-2099	650
2100-2299	750

S4551 with 2 end bolts and 2 side bolts, hook bolt type

L	a
1900-1999	550
2000-2099	650
2100-2299	750

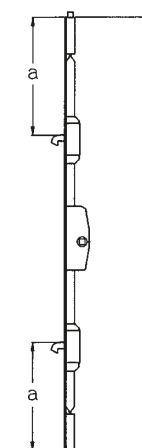

S8151 with 2 end bolts and 1 side bolt

L	b
390-549	-
550-1799	90*

S8151 with 2 end bolts and 2 side bolts

L	a
1800-1899	550
1900-2099	650
2100-2299	750

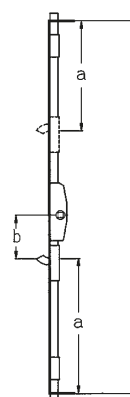

*) Applies to handle height (H) = centre plus/minus 235 mm. For other handle heights, the bolt is positioned at the centre of the espagnolette length.

Minimum bolt placing for side bolt, wedge bolt type

ITEM NO.	BOTTOM BOLT A		BELOW LOCK HOUSING B		ABOVE LOCK HOUSING C	TOP BOLT D
		Placing between these measurements is not possible		Placing between these measurements is not possible		
S1151	55	55-80	65	65-125	135	55
S1151 top	55	55-80	65	65-125	135	100
S1151 bottom	125	125-146	65	65-125	135	125
S1451	200		65	65-125	135	200
S3151	55	55-80	65	65-181	170	55
S3151 top	55	55-80	65	65-181	170	100
S3151 bottom	125	125-146	65	65-181	170	125
S3451	200		65	65-181	170	200
S3251	55	55-80	65	65-190	234	55
S3251 top	55	55-80	65	65-190	234	100
S3251 bottom	125	125-146	65	65-190	234	125
S3551	200		65	65-190	234	200
S1601, S1605	80		65	65-145	170	80
S1601, S1605 top	80		65	65-145	170	125
S1601, S1605 bottom	125		65	65-145	170	80
S8251	125		90	90-200	135	137
M5601	140		300		270	110
M5101, M5201	140		330		330	110
M6101	140		300		330	110
M5701	140		300		240	110

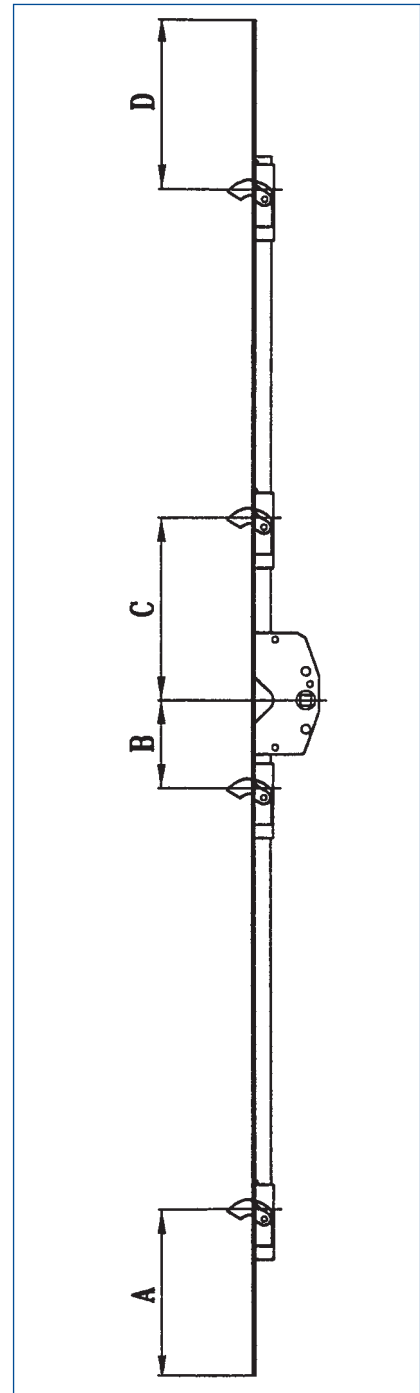

Minimum bolt placing for side bolt, hook bolt type



ITEM NO.	BOTTOM BOLT A	BELOW LOCK HOUSING B		ABOVE LOCK HOUSING C	TOP BOLT D
			Placing between these measurements is not possible		
S4151	115	65	65-200	210	70
S4151 top	115	65	65-200	210	60
S4151 bottom	180	65	65-200	210	125
S4451	230	65	65-200	210	210
S4251	115	210		270	70
S4251 top	115	210		270	160
S4251 bottom	180	210		270	125
S4551	230	210		270	210
S4551	230	90	90-150	170	210
S2451	115	90	90-150	170	70
S2151 top	115	90	90-150	170	160
S2151 bottom	180	90	90-150	170	125
M6102	125	320		310	100
M5002, M5202	125	320		310	100
M5602	125	290		250	100
M5703	130	310		250	110

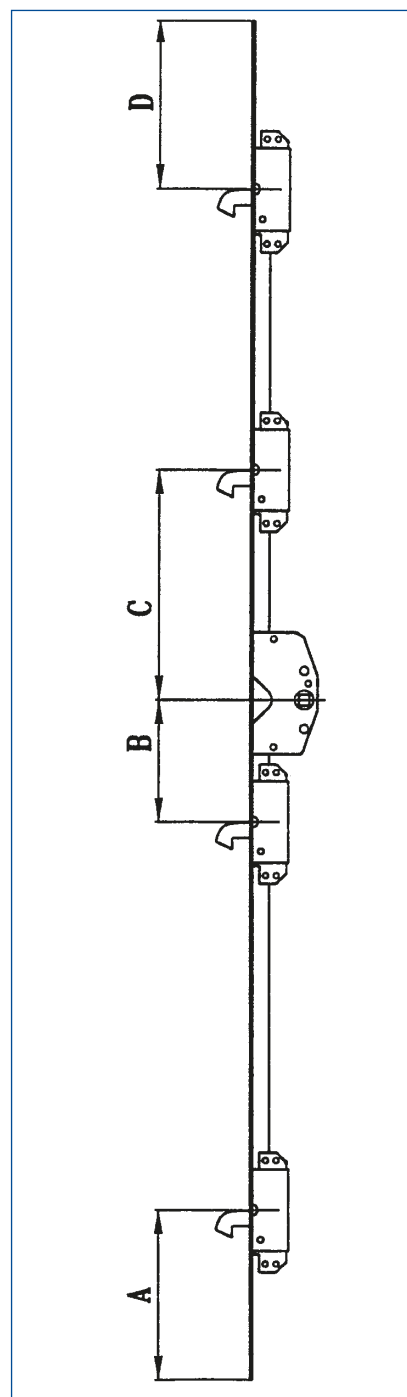

Lock housing

Instructions for milling. Measurements in mm.

Espagnolettes

ASSA S1161, S1163, S1165, S1162
ASSA S1166, S1453, S1164
ASSA S1167

Backset (D)/Lock depth (L)

18/28
28/38
33/43

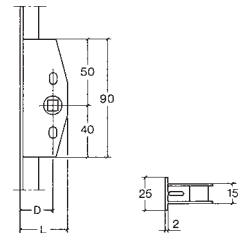

Made-to-measure espagnolettes

ASSA S1451, S1151, S2451, S2151
ASSA S1153, S1452, S2452, S1167

Backset (D)/Lock depth (L)
18/28, 25/35, 28/38, 33/43, 40/50
18/28, 25/35, 28/38, 33/43, 40/50

Espagnolettes

ASSA S3157
ASSA S3188

Backset (D)/Lock depth (L)

28/41
33/46

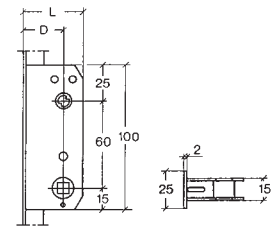

Made-to-measure espagnolettes

ASSA S3151, S3451, S4151, S4451
ASSA S3452, S4452

Backset (D)/Lock depth (L)

28/41, 31/44, 33/46, 40/53
28/41, 31/44, 33/46, 40/53

Espagnolettes

ASSA S8551, S8552

Backset (D)/Lock depth (L)

40/53

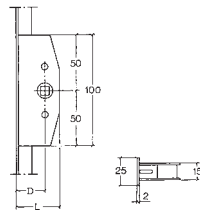

Made-to-measure espagnolettes

ASSA S8151
ASSA S8452, S454, S8457, S8251

Backset (D)/Lock depth (L)

18/31, 23/36, 28/41, 40/53
40/53

Espagnolette

ASSA S1604

Backset (D)/Lock depth (L)

28/35

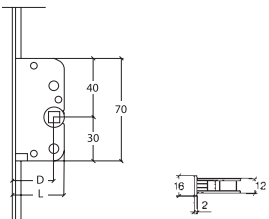

Made-to-measure espagnolettes

ASSA S1601, S1605

Backset (D)/Lock depth (L)

25/32, 28/35

Made-to-measure espagnolettes

ASSA S3251, S3551, S4251, S4551

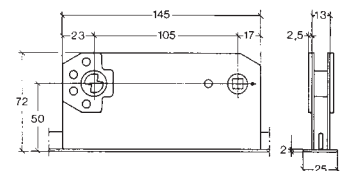

Lock housing

Instructions for milling. Measurements in mm.

Made-to-measure espagnolette

	Backset (D)/Lock depth (L)
ASSA S8158	18/31, 20/35

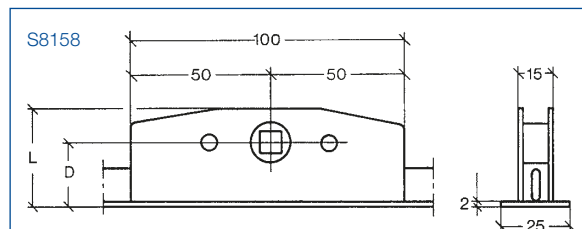

Made-to-measure espagnolettes

	Backset (D)/Lock depth (L)
ASSA S1751, S1754	26/35, 28/38

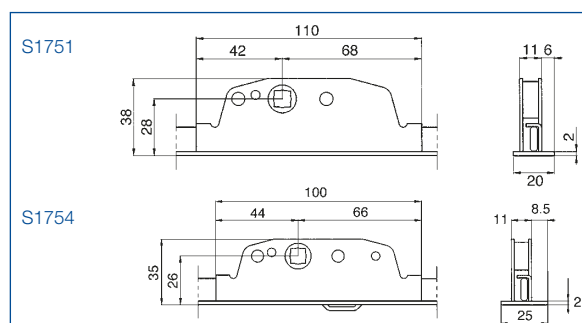

Espagnolette

	Backset (D)/Lock depth (L)
ASSA 5600	28/36

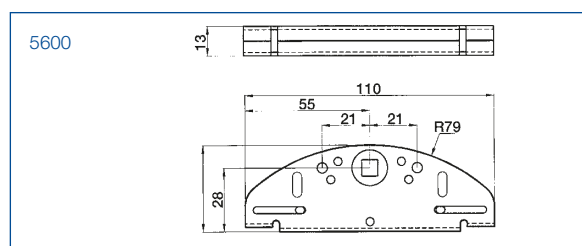

Multi point lock

M5100
M5000
M5002
M5001
M5101
M5017
M5200
M5202
M5201

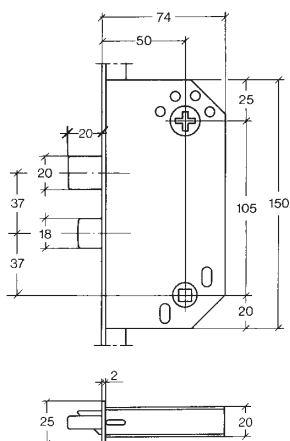

Multi point lock

M5600
M5602
M5601

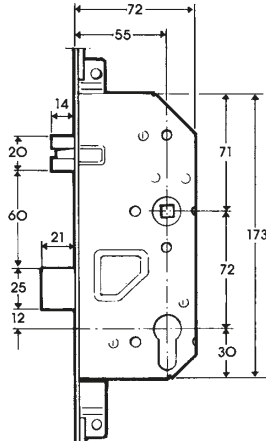

Multi point lock Evo

M5300
M5400
M5500

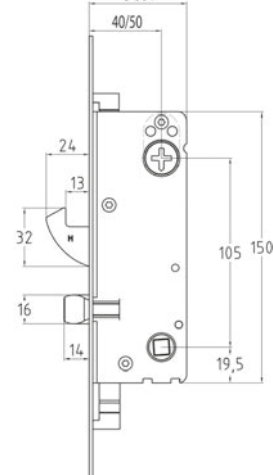

End bolts and transmission

Instructions for milling. Measurements in mm.

End bolt, grab bolt type

with and without transmission for mortised casement stays ASSA 150, 150S, 160 and 160S. Available with transmission at the top of espagnolette ASSA S1453, and top or bottom of made-to-measure espagnolette ASSA S1451, S2451, S3451, S3551, 4551, 1452, 2452, 3452, 4452. Available without transmission for made-to-measure espagnolette ASSA S8452 and S8454.

End bolt, wedge bolt type

for ASSA S8151 and S8251. The espagnolette comes with unbent plate edges. Bending is done during installation.

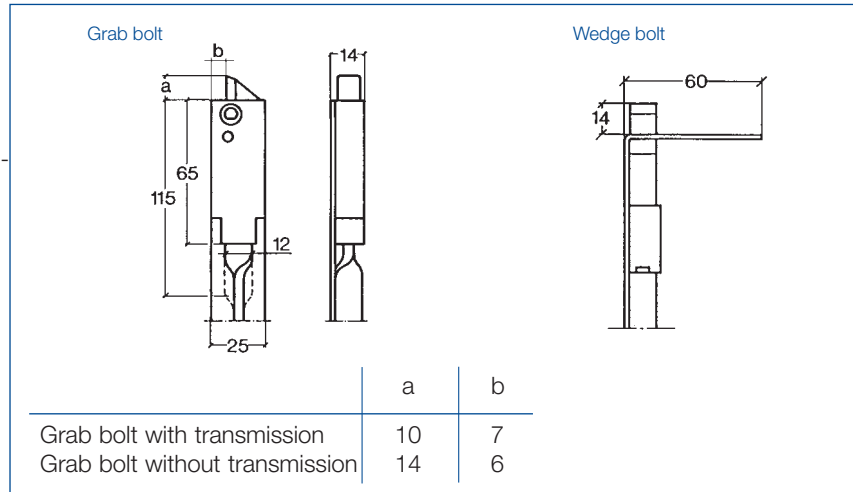

End bolt, spring bolt type

for ASSA S8551.

End bolt, round, cone-shaped type

for ASSA S8552, S8452, S8454.

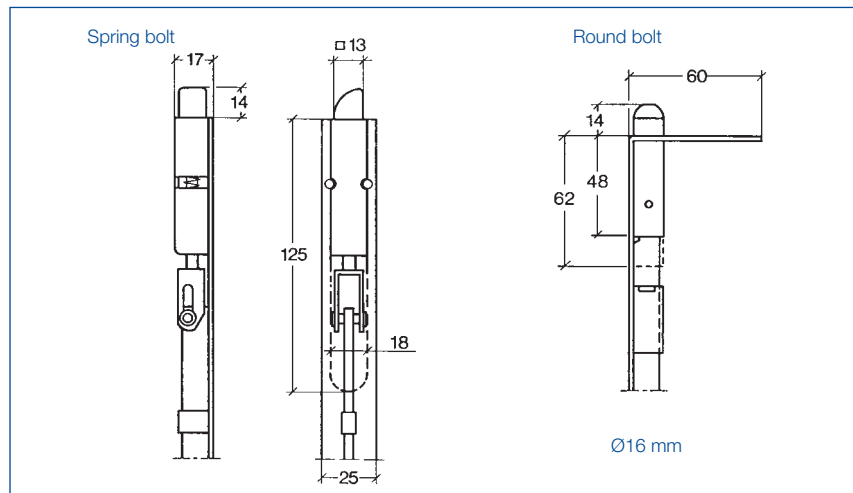

End bolt, grab bolt type

for ASSA S1751, S1754.

Transmission for casement stays ASSA 150, 150S, 160 and 160S on espagnolette with side bolts only.

Transmission for casement stays ASSA 750A and 760A on espagnolette ASSA S1601 and S1605

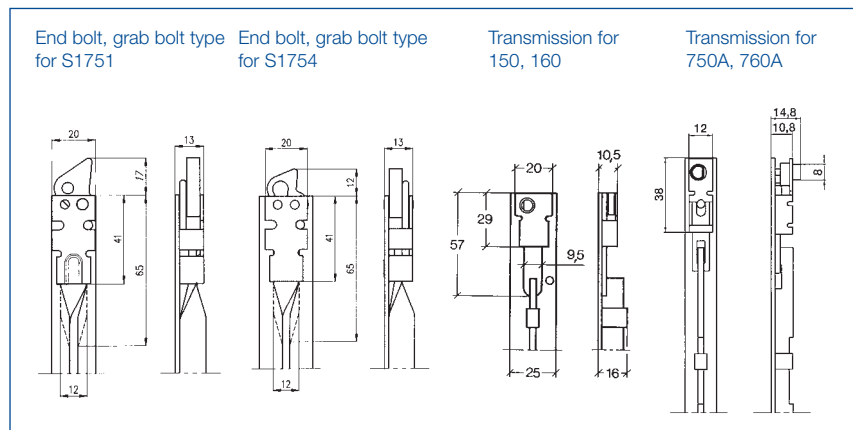

Side bolts

Instructions for milling. Measurements in mm.

Wedge bolt, large

Mounts into milling slot for the bolt bar.
See page E 98.

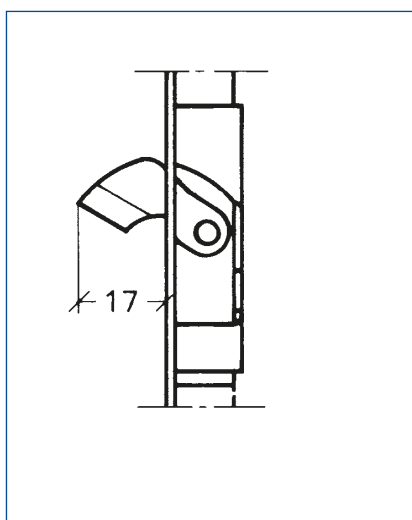

Wedge bolt, small

Mounts into profile groove according to Euro norm.
See page E 98.

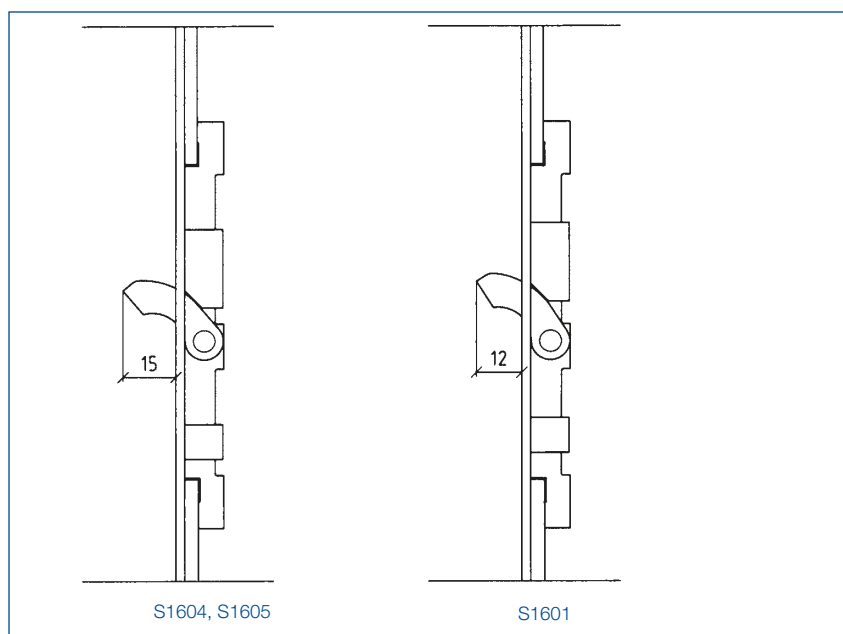

Hook bolt with bolt housing, measurement drawing

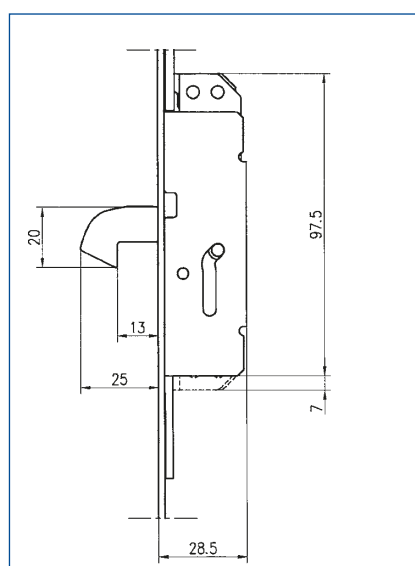

Hook bolt with bolt housing,
vertical bar for ASSA S4151, S4451,
S4251, S4551, S2451, S2151.
Milling measurements:

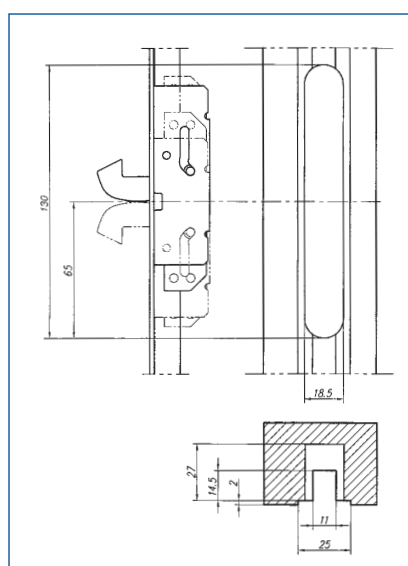

Hook bolt with bolt housing,
horizontal bar for ASSA M5200, M6100,
M6000, M6102, M5100, M5000,
M5002, M5004.
Milling measurements:

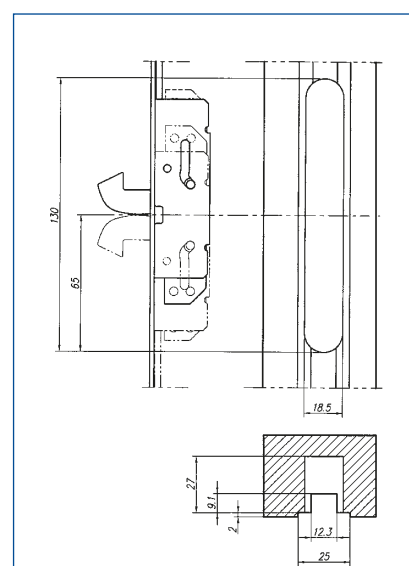

Espagnolette, security receiver and hook bolt

Instructions for milling. Measurements in mm.

Espagnolette with wedge bolt, 25 mm face plate

Dotted line indicates slot for lock housing, page E 94–95.

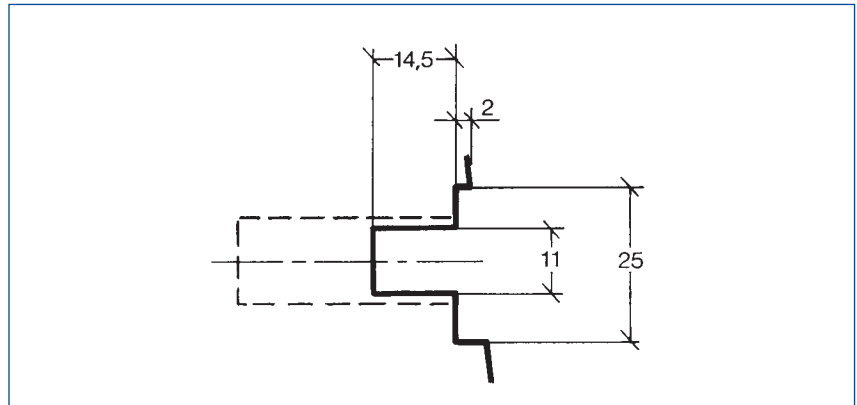

Espagnolette S1601, S1605 and S1604

For side bolt, no special slot is needed. Dotted line indicates slot for lock housing, page E 94.

Euro-note

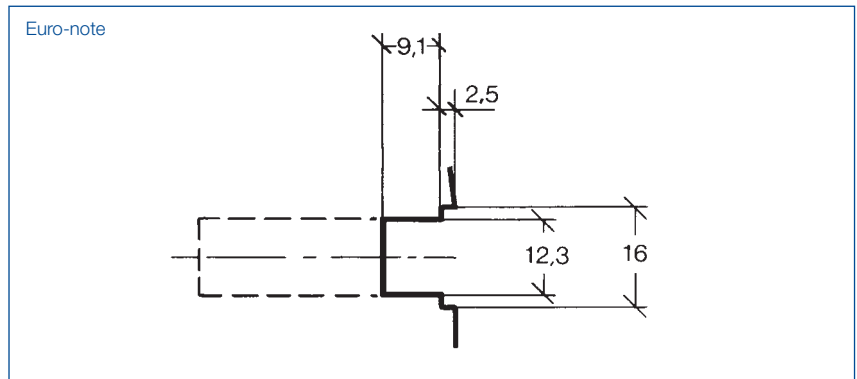

Receiver 4700

Cut for hook bolt and receiver ASSA 4700

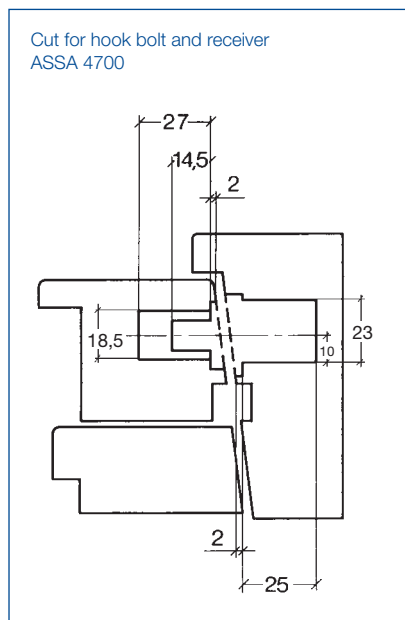

Milling for receiver ASSA 4700

